

# Line

## TIPOLOGIE DI APERTURA

- SCORREVOLE
- SCORREVOLE CON TRASCINAMENTO
- FISSO TRA MURI
- ROTOTRASLANTE
- BILICO
- SCORR. INTERNO MURO
- BATTENTE

## TYPES OF OPENING SYSTEMS

- SLIDING DOOR
- SLIDING DOOR WITH DRAG
- FIXED BETWEEN WALLS
- ROTOTRANSLATING
- PIVOT
- POCKET DOOR
- SWING

La collezione Line è caratterizzata da un'anta con telaio di alluminio (come quello della collezione Mitica) con vetro centrale a cui vengono applicati traversini in alluminio su entrambe le facce del vetro. Personalizzabili per posizione, verso e passo permettono di realizzare diverse configurazioni estetiche in grado di rispondere a differenti esigenze stilistiche e progettuali.

*The Line collection is characterised by a door with an aluminium frame (like the same of the Mitica collection) with a central glass pane to which are applied aluminium crosspieces on both sides. These doors, for which the position, direction and pitch can be customised, allow you to create three different aesthetic configurations that are able to meet different stylistic and design needs.*

La colección Line está caracterizada por una hoja con bastidor de aluminio (al igual que en la colección Mitica) con cristal central al que se le aplican viguetas de aluminio en ambas caras del cristal. Son personalizables por posición, orientación y paso y, permiten

realizar, tres configuraciones estéticas distintas capaces de responder a las diferentes necesidades estilísticas y proyectuales.

*La collection Line est caractérisée par une porte avec un châssis en aluminium (comme celui de la collection Mitica) avec un verre central sur lequel des traverses en aluminium sont appliquées sur les deux côtés. Personnalisables pour la position, le sens et le pas, elles permettent de réaliser différentes configurations esthétiques pour répondre aux différentes exigences de style et de conception.*

Die Kollektion Line zeichnet sich durch einen Türflügel mit Aluminiumrahmen (wie bei der Kollektion Mitica) mit mittiger Glasscheibe aus, auf der Querleisten aus Aluminium auf beiden Seiten der Glasscheibe aufgesetzt werden. Die Position, die Richtung und der Abstand der Querleisten sind personalisierbar, sodass sich verschiedene ästhetische Konfigurationen schaffen lassen, die die unterschiedlichsten Stil- und Projektanforderungen erfüllen.

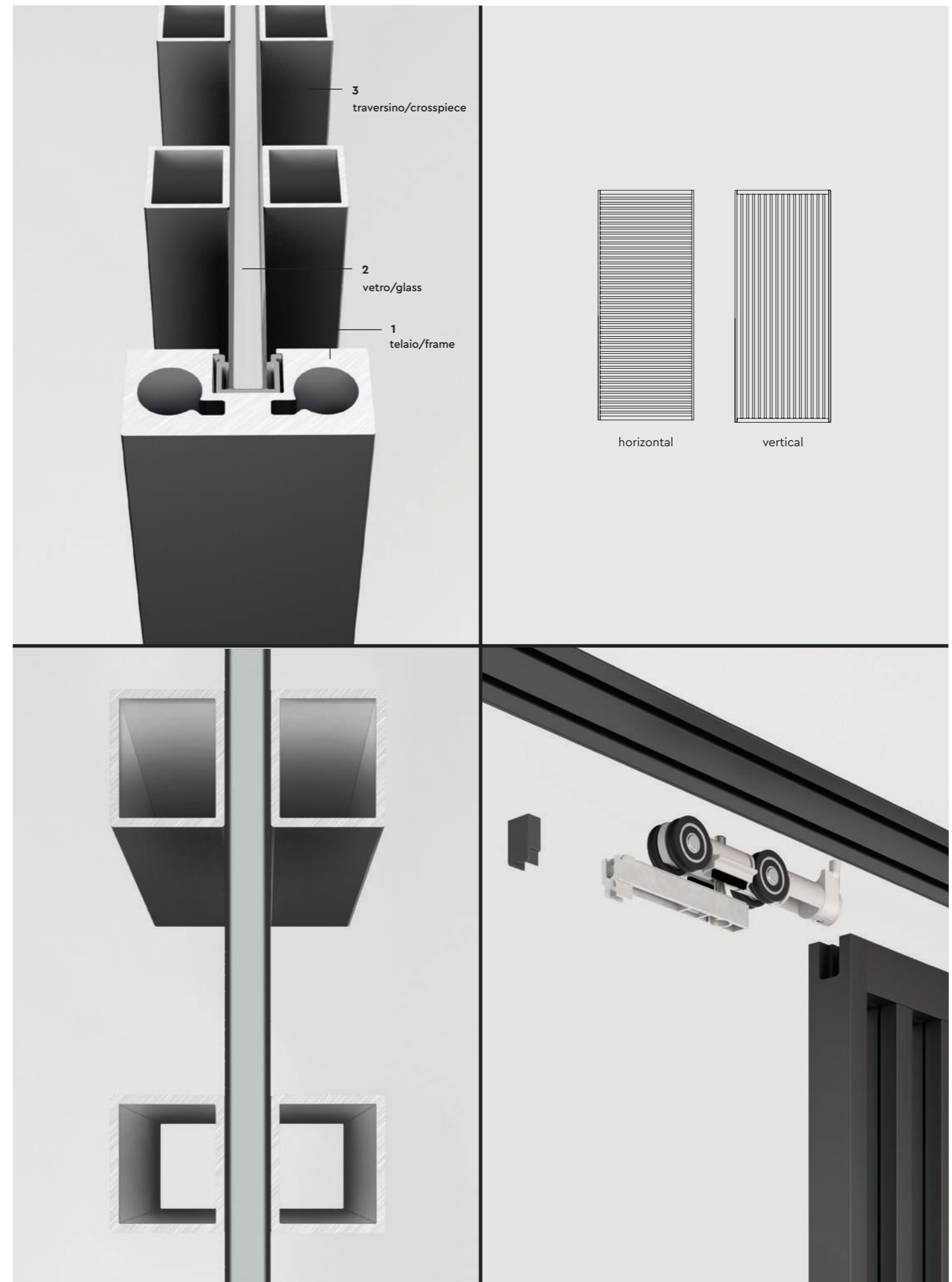





▲  
**apertura:** scorrevole  
**telaio:** rovere naturale  
**specchiatura:** vetro neutro extrachiario  
**maniglia:** X14  
**dimensioni vano:** 4000×2700 mm

**opening:** sliding  
**frame:** rovere naturale  
**door panel:** extra clear glass  
**handle:** X14  
**compartment size:** 4000×2700 mm



►  
**apertura:** scorrevole  
**telaio:** rovere noce canaletto  
**specchiatura:** vetro neutro extrachiaro  
**maniglia:** X14  
**dimensioni anta:** 1300×2700 mm

**opening:** sliding  
**frame:** rovere noce canaletto  
**door panel:** extra clear glass  
**handle:** X14  
**door size:** 1300×2700 mm



## BINARIO A 1 VIA / 1 WAY TRACK

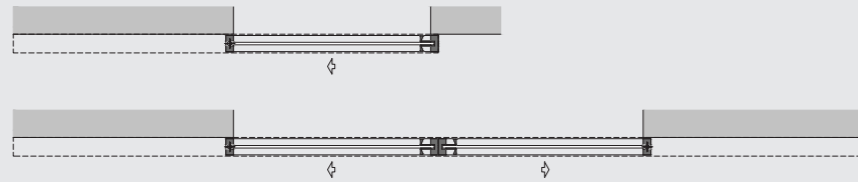

## BINARIO A 2 VIE / 2 WAY TRACK

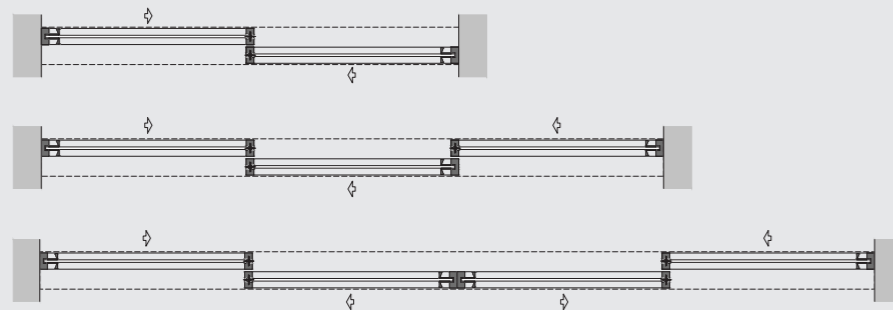

## BINARIO A 3 VIE / 3 WAY TRACK

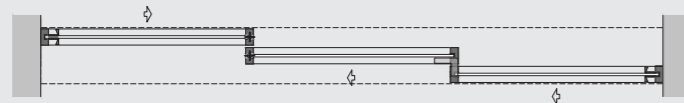

## BINARIO A 4 VIE / 4 WAY TRACK

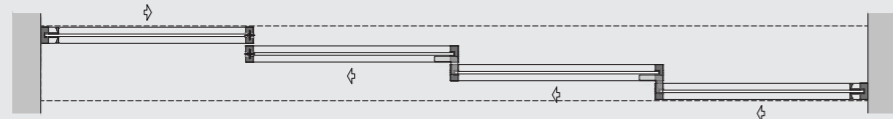

## PANNELLO FISSO / FIXED PANEL

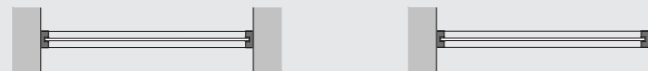

## LINE HORIZONTAL

L MAX = 1550

H MAX = 2900

## LINE VERTICAL

L MAX = 1500

H MAX = 3200

CARATTERISTICHE TECNICHE  
TECHNICAL FEATURES

Il perno di guida dell'anta scorrevole rientra all'interno del telaio del pannello facilitandone il montaggio. Il sistema antisbandieramento (opzionale) è composto da un perno ammortizzato la cui ruota in poliuretano crea attrito a contatto con il pavimento aiutando l'anta a non sbandierare. La maniglia mod. X14 verniciata nella stessa finitura del telaio ha un'altezza standard e, a richiesta del cliente può essere eliminata.

*The sliding door's guide pin retracts into the panel frame, thereby facilitating the assembly. The anti-swing system (accessory) includes a shock-absorbing pin with a polyurethane wheel that creates friction when in contact with the floor preventing the door from swinging on its own. The handle model X14, painted in the same finish as the leaf frame, has a standard height, but it can also be eliminated.*

El perno de guía de la hoja corredera se encuentra dentro del marco del panel, lo que facilita el montaje. El sistema antibalaceo (opcional) está formado por un perno amortiguado cuya rueda de poliuretano genera fricción en contacto con el suelo y ayuda a la hoja a no balancearse. La manilla mod. X14

pintada con el mismo acabado que el marco tiene una altura estándar y, a petición del cliente, se puede eliminar.

*Le pivot de guidage de l'ouvrant coulissant est poussé à l'intérieur du cadre du panneau, ce qui facilite le montage. Le système anti-fluctuation (en option) est constitué d'un pivot amorti dont la roue en polyuréthane crée un frottement au contact du sol, ce qui permet à l'ouvrant de ne pas fluctuer. La poignée mod. X14 peinte avec la même finition que le cadre a une hauteur standard mais, à la demande du client, elle peut être éliminée.*

Der Führungsbolzen der Schiebetür rückt in den Rahmen des Paneels ein und erleichtert dadurch die Montage. Das System mit Führungszapfen (Optional) setzt sich aus einem gedämpften Bolzen mit einer Rolle aus Polyurethan zusammen, der bei Kontakt mit dem Fußboden Reibung erzeugt, sodass die Tür ihre Stabilität nicht verliert. Der Griff Modell X14 ist in der gleichen Oberfläche wie der Rahmen lackiert, hat eine Standardhöhe und kann auf Anfrage des Kunden eliminiert werden.





▲  
**apertura:** rototraslante  
**telaio:** rame brunito  
**specchiatura:** vetro neutro extrachiaro  
**maniglia:** X5-R  
**dimensioni vano:** 3300×2900 mm

**opening:** rototranslating  
**frame:** rame brunito  
**door panel:** extra clear glass  
**handle:** X5-R  
**compartment size:** 3300×2900 mm

## SOLUZIONE CON 2 ANTE / SOLUTION WITH 2 DOORS

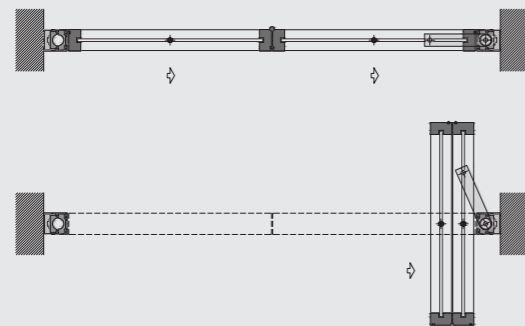

## SOLUZIONE CON 3 ANTE / SOLUTION WITH 3 DOORS

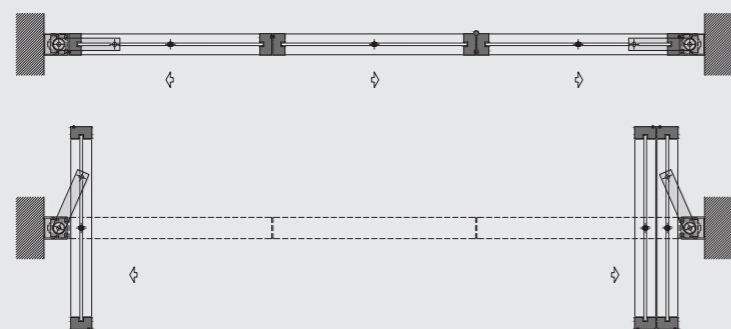

## SOLUZIONE CON 3 ANTE (TUTTE SU UN LATO) / SOLUTION WITH 3 DOORS (ALL ON ONE SIDE)

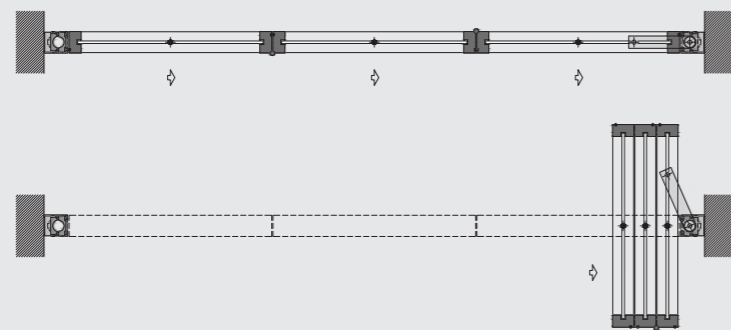

TUTTE LE SOLUZIONI A PAGINA 314-315 / ALL SOLUTIONS ON PAGE 314-315

CARATTERISTICHE TECNICHE  
TECHNICAL FEATURES

Il sistema rototraslante permette ai pannelli della composizione di ruotare sul proprio interasse e traslare fino alla parete senza la necessità di alcun binario a pavimento. Questa tecnologia permette di avere pannelli larghi fino a 130 cm, che quando chiusi sono perfettamente allineati allo stesso piano, e quando aperti liberano oltre il 90% del vano di passaggio.

*The rototranslating system allows the panels to rotate on their own centre distance and move up to the wall without the need for any floor track. This technology allows you to have panels up to 130 cm wide, which, when closed, are perfectly aligned to the walls and, when open, free up over 90% of the passageway.*

El sistema rototraslante permite que los paneles de la composición giren sobre su eje y se desplacen hasta la pared sin necesidad de ningún riel en el suelo. Esta tecnología permite tener paneles de hasta 130 cm de ancho que, cuando están cerrados, están perfectamente alineados al mismo nivel y, cuando están abiertos, liberan más del 90% del espacio de paso.

*Le système de roto-translation permet aux panneaux de l'ensemble de tourner sur leur propre entraxe et de se translater jusqu'au mur sans qu'aucun rail au sol ne soit nécessaire.*

*Cette technologie permet d'utiliser des panneaux d'une largeur allant jusqu'à 130 cm qui, lorsqu'ils sont fermés, sont parfaitement alignés sur le même plan et qui, lorsqu'ils sont ouverts, libèrent plus de 90 % de l'espace de passage.*

Das Drehschiebesystem ermöglicht das Drehen der Paneele auf der eigenen Achse und ihr Verschieben zur Wand, ohne dass eine Bodenschiene erforderlich ist. Diese Technologie erlaubt die Installation von Paneelen mit einer Breite bis 130 cm, die nach dem Schließen perfekt bündig sind und nach dem Öffnen 90% des Durchgangs freigeben.



▲  
**apertura:** bilico senza stipiti  
**telaio:** testa di moro  
**specchiatura:** vetro neutro extrachiario  
**dimensioni vano:** 8000×2900 mm

**opening:** pivot without jambs  
**frame:** testa di moro  
**door panel:** extra clear glass  
**compartment size:** 8000×2900 mm





#### CARATTERISTICHE TECNICHE TECHNICAL FEATURES

La cerniera dell'apertura a bilico è integrata nel profilo del telaio enfatizzando la pulizia delle forme eliminando qualsiasi predisposizione preliminare. Il sistema permette l'apertura dell'anta in entrambe le direzioni, con l'arresto automatico in chiusura e con il fermo dell'anta a 90°.

*The hinge of the pivot opening system is integrated into the frame profile, emphasising the clean shapes and making any previous arrangements unnecessary. The system allows the door to be opened in both directions, stopping automatically when closing and with a 90-degree doorstop.*

La bisagra de la apertura pivotante está incorporada en el perfil del marco acentuando la nitidez de las formas eliminando cualquier predisposición previa. El sistema permite abrir la hoja en ambas direcciones, con el tope de cierre automático y el tope de la hoja a 90°.

*La charnière à pivot est intégrée dans le profil du cadre, ce qui exalte la linéarité des formes et élimine toute préparation préalable. Le système permet l'ouverture de la porte dans les deux sens, avec l'arrêt automatique en fermeture et l'arrêt à 90°.*

*Das Scharnier für das Öffnen der Pivot-Tür ist in das Profil des Rahmens integriert und unterstreicht nicht nur die Reinheit der Formen, sondern eliminiert auch alle Vorbereitungen im Vorfeld. Das System erlaubt das Öffnen der Tür in beide Richtungen mit automatischem Halt in der geschlossenen Position und mit Anschlag der Tür bei 90°.*

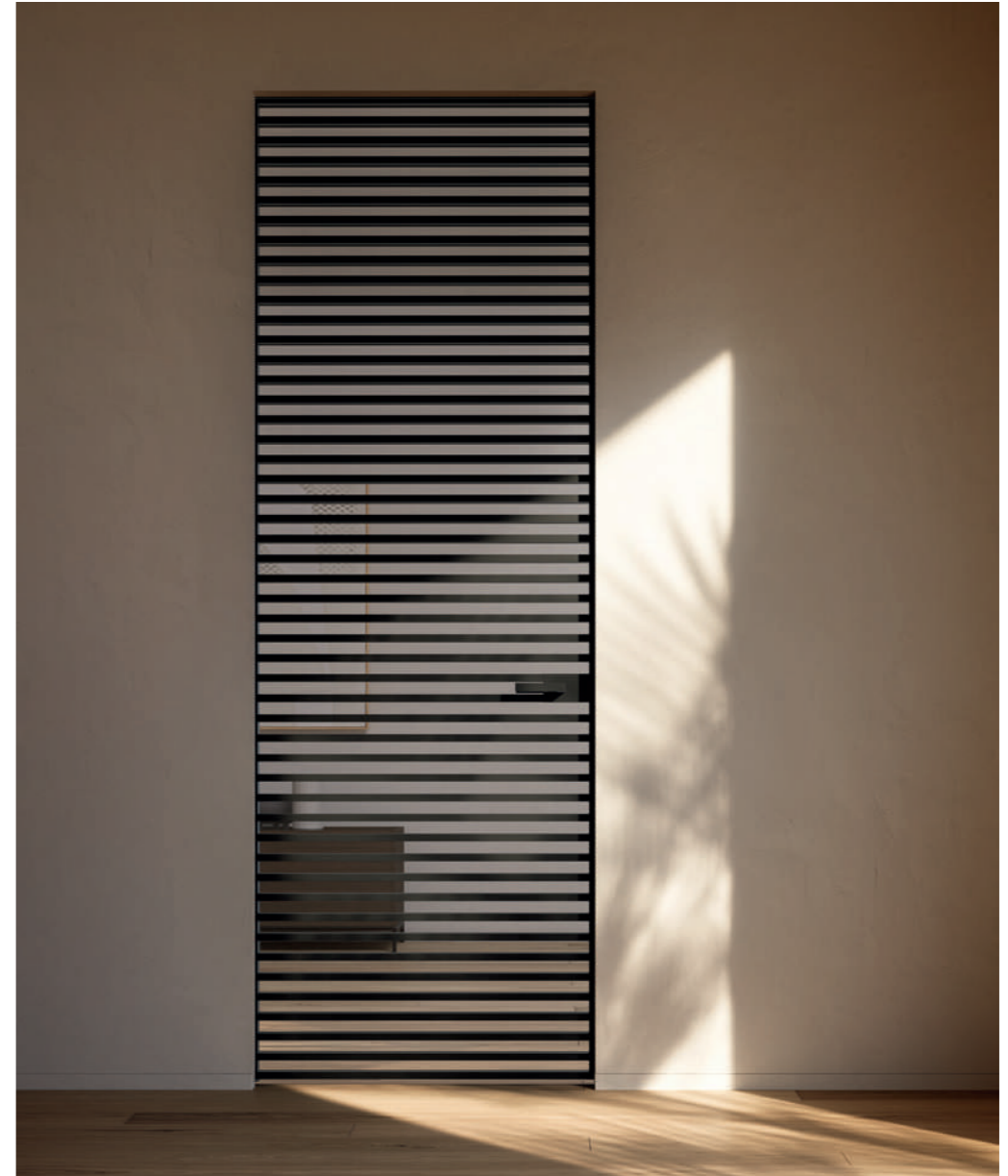

▲  
**anta:** Line horizontal  
**stipite:** raso  
**telaio:** nero  
**specchiatura:** vetro neutro extrachiaro  
**maniglia:** Elle  
**dimensioni:** 850×2400 mm

**door:** Line horizontal  
**jamb:** raso  
**frame:** black  
**door panel:** extra clear glass  
**handle:** Elle  
**size:** 850×2400 mm



▲  
**anta:** Line vertical  
**stipite:** raso (testa di moro)  
**anta:** noce canaletto  
**specchiatura:** vetro reflex bronzo  
**maniglia:** Elle  
**dimensioni:** 800×2600 mm

**door:** Line vertical  
**jamb:** raso (testa di moro)  
**frame:** noce canaletto  
**door panel:** bronze reflex glass  
**handle:** Elle  
**size:** 800×2600 mm



### Stipiti con coprifili minimal

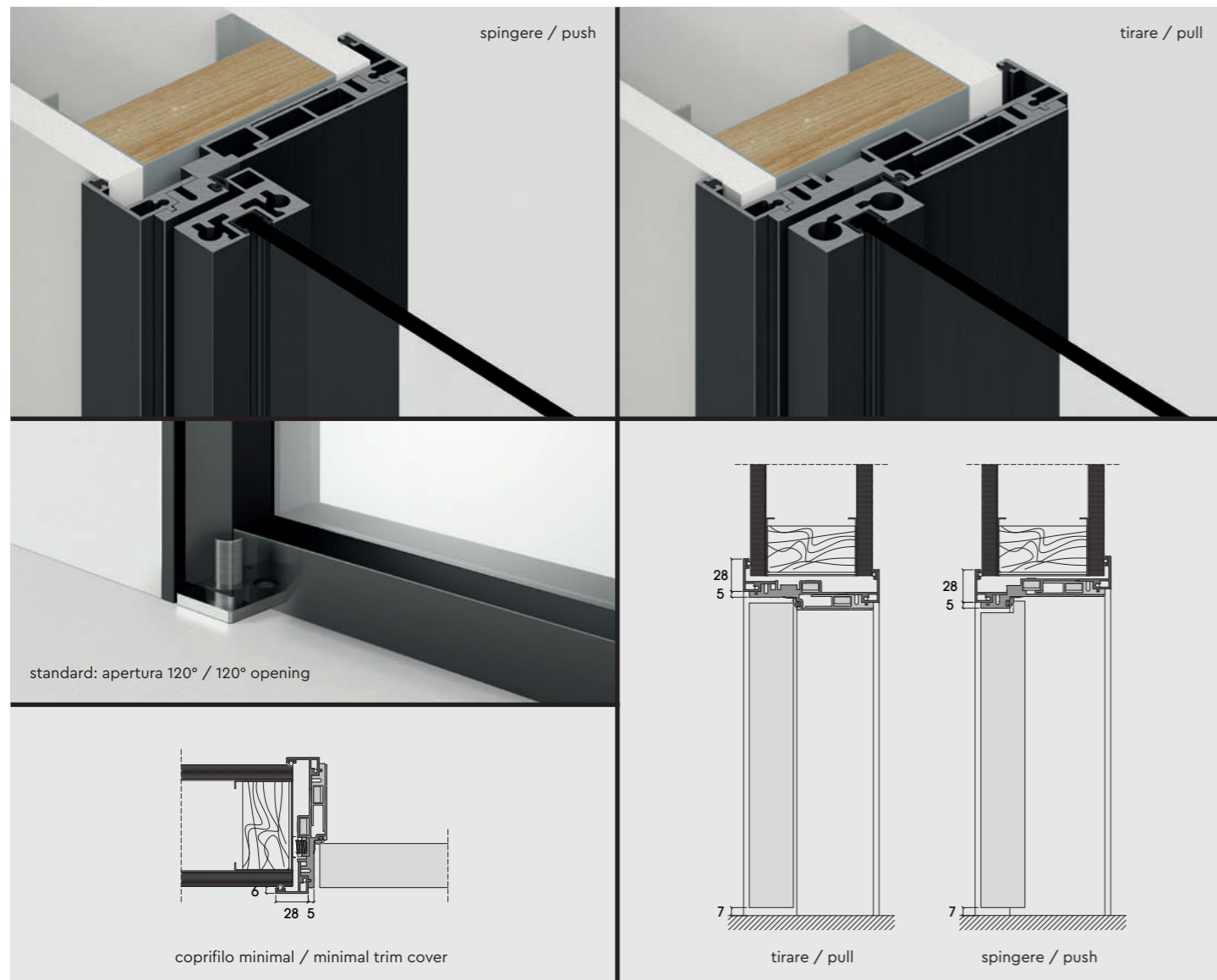

### Stipite raso

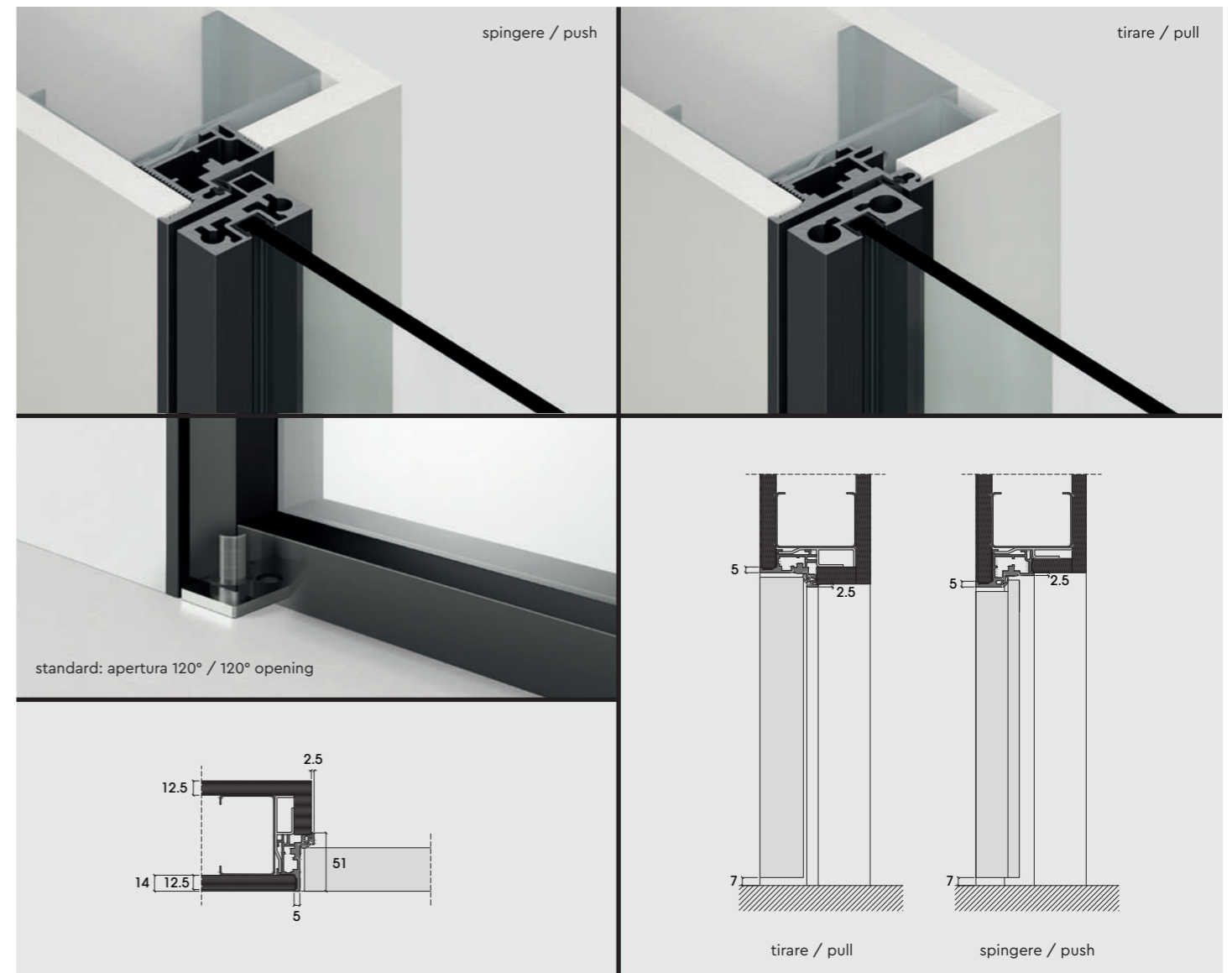

SU RICHIESTA / ON REQUEST

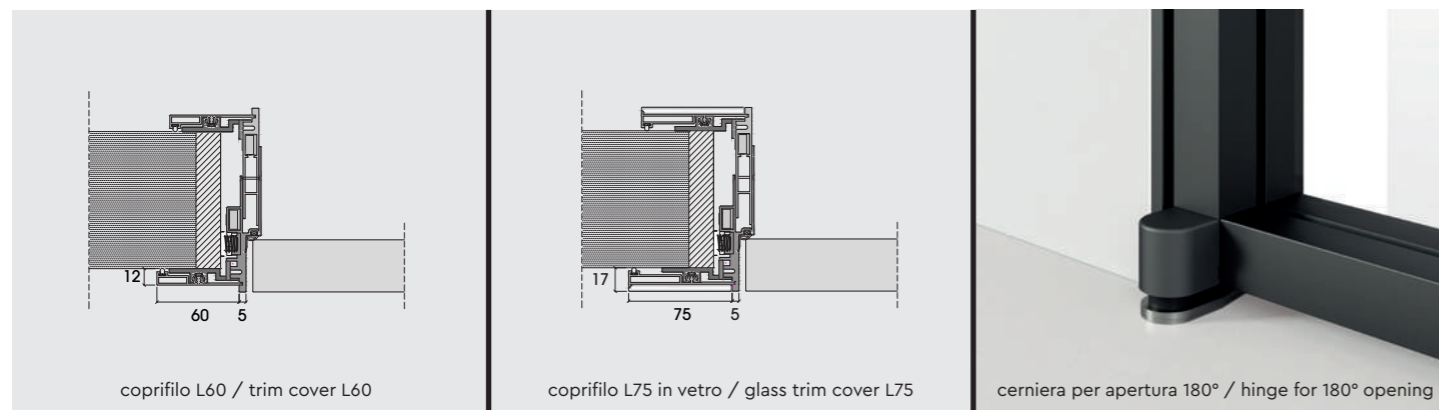

SU RICHIESTA / ON REQUEST

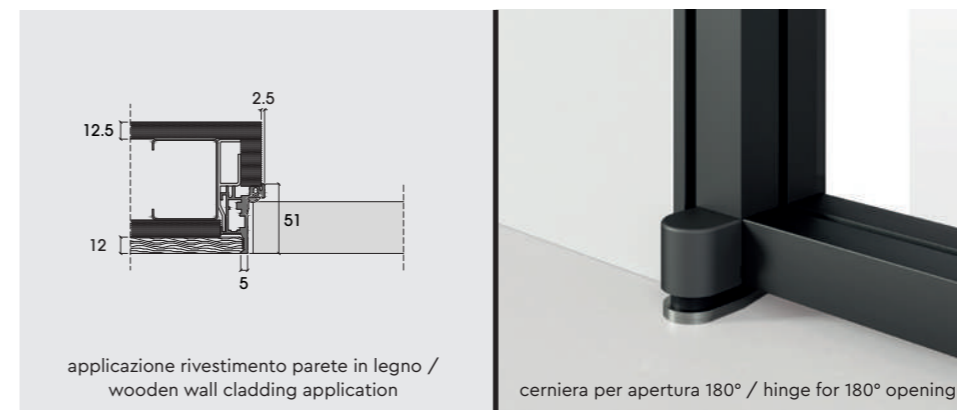

### Stipite slim

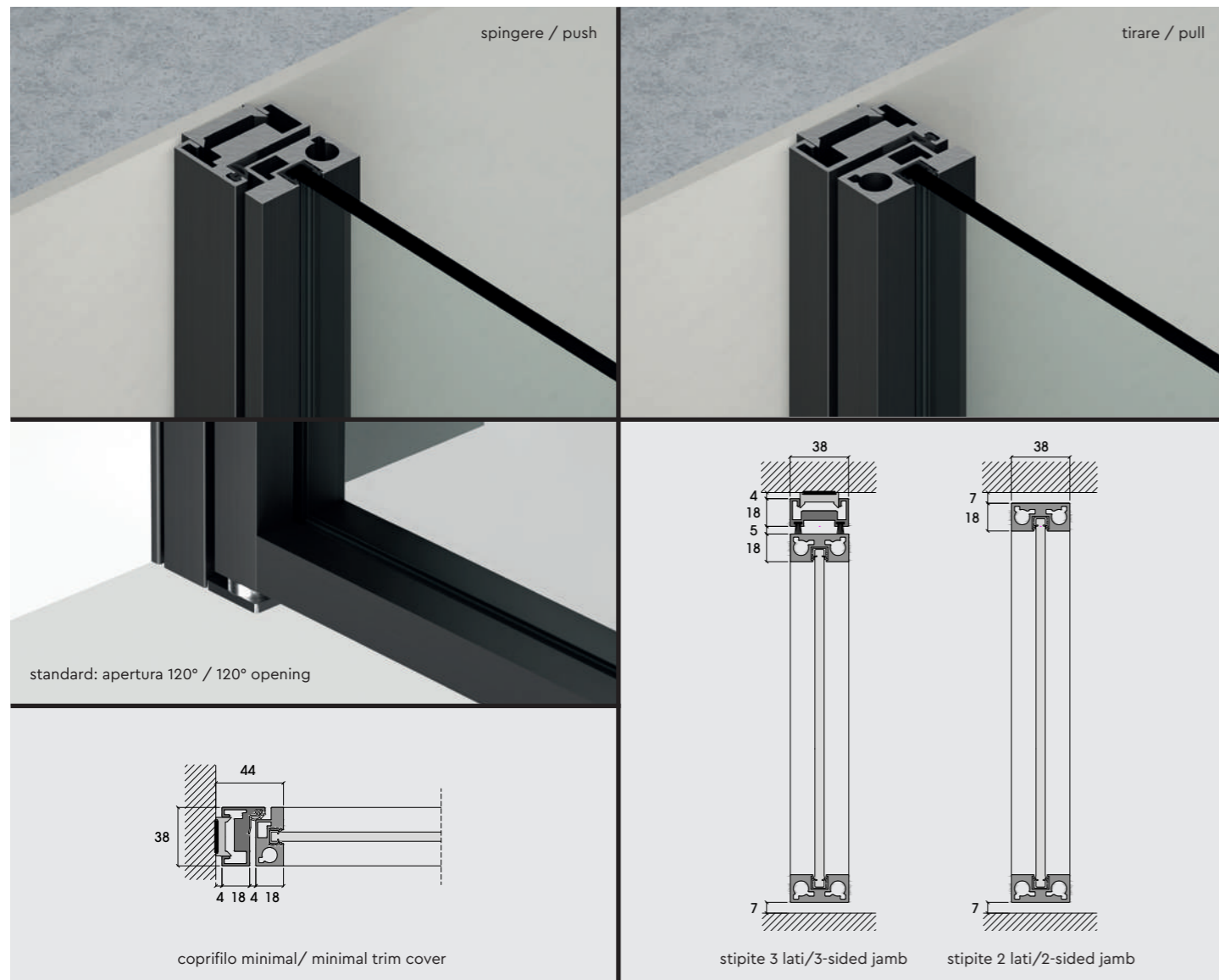

### Stipite corner

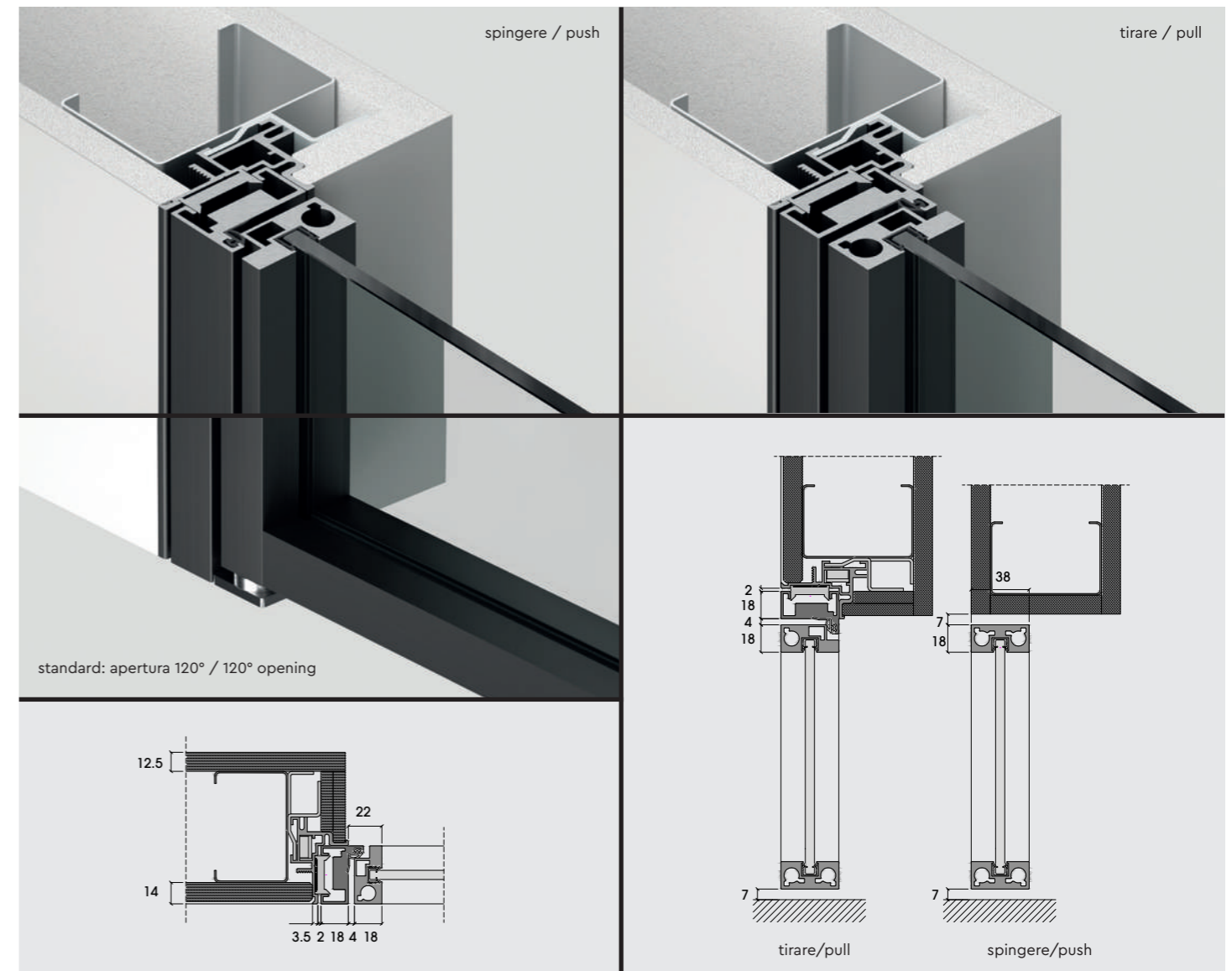

SU RICHIESTA / ON REQUEST

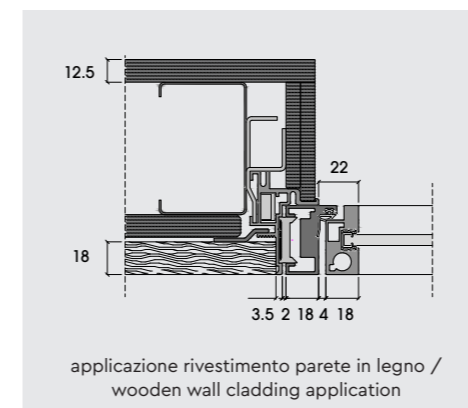



▲  
**anta:** Line vertical  
**stipite:** corner 3 lati  
**telaio:** noce canaletto  
**specchiatura:** vetro neutro extrachiaro  
**maniglia:** X8 con dispositivo magnetico  
**dimensioni:** 1000×3200 mm

**door:** Line vertical  
**jamb:** corner 3 sides  
**frame:** noce canaletto  
**door panel:** extra clear glass  
**handle:** X8 with magnetic device  
**size:** 1000×3200 mm



## Stipite slim

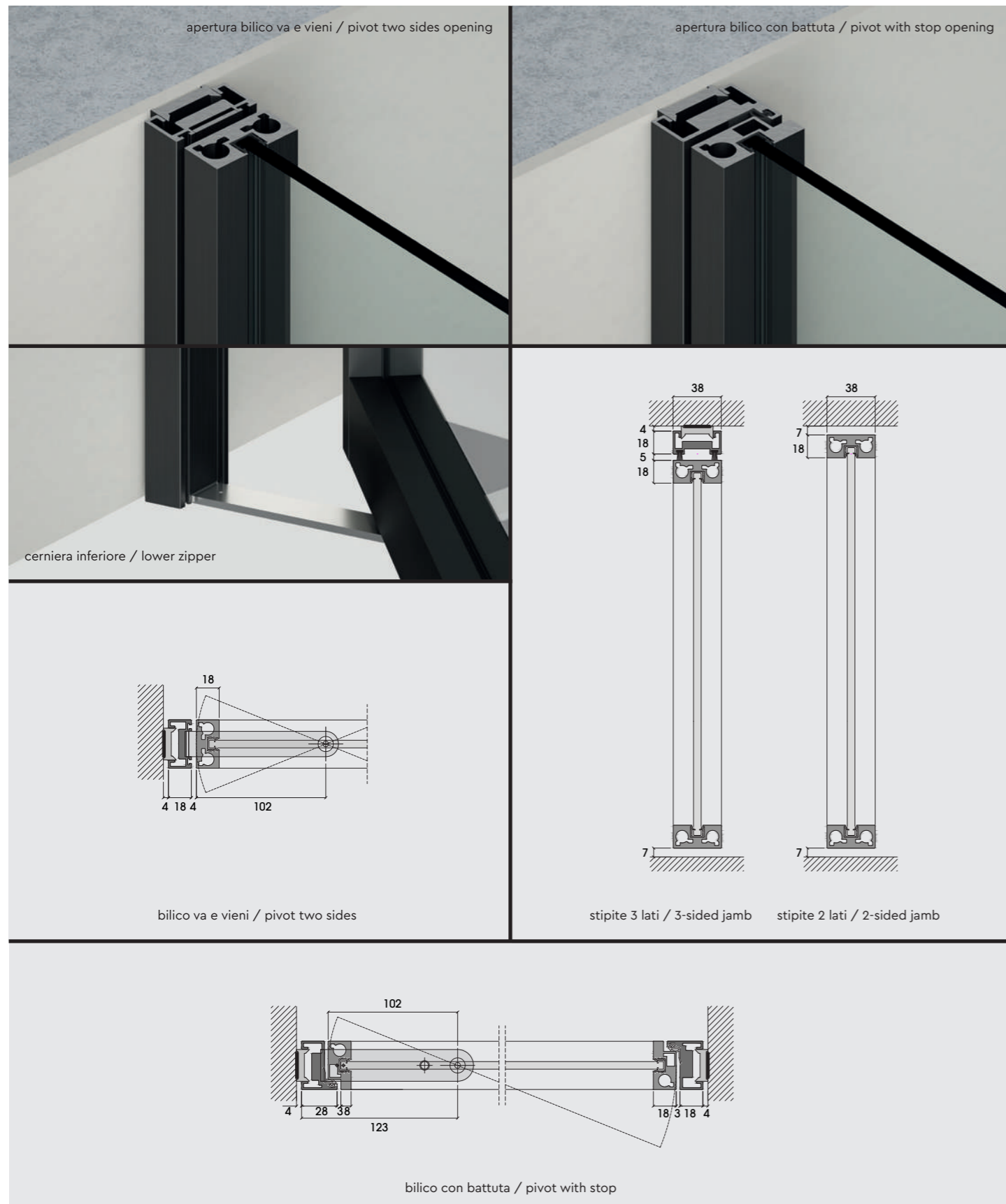

## Stipite corner

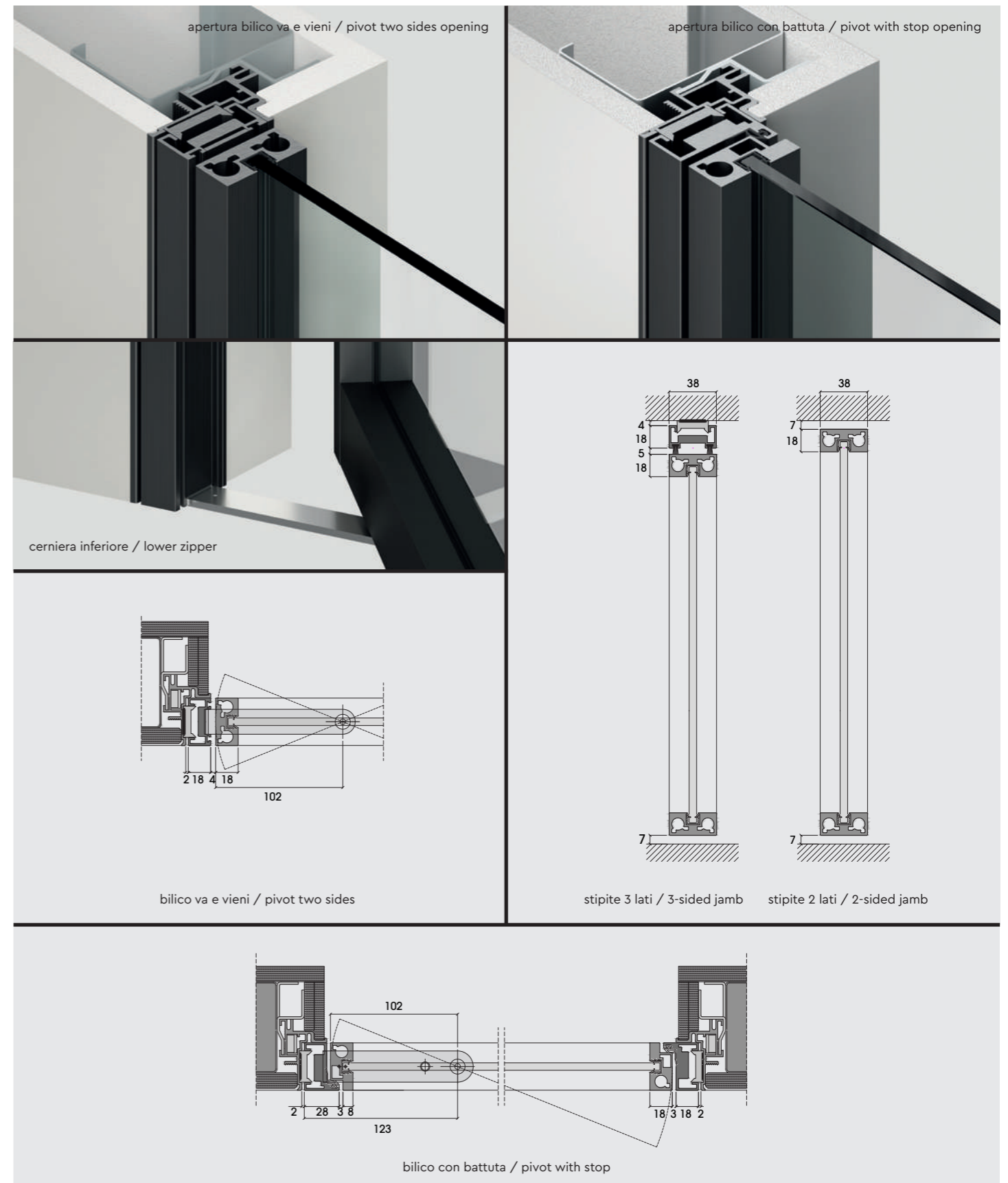



▲  
**anta:** Line horizontal  
**controtelaio:** stipse per coprifili  
**telaio anta:** testa di moro  
**specchiatura:** vetro neutro extrachiario  
**maniglia:** X14  
**dimensioni:** 1600×2400 mm

**door:** Line horizontal  
**counterframe:** jamb for architraves  
**door frame:** testa di moro  
**door panel:** extra clear glass  
**handle:** X14  
**size:** 1600×2400 mm

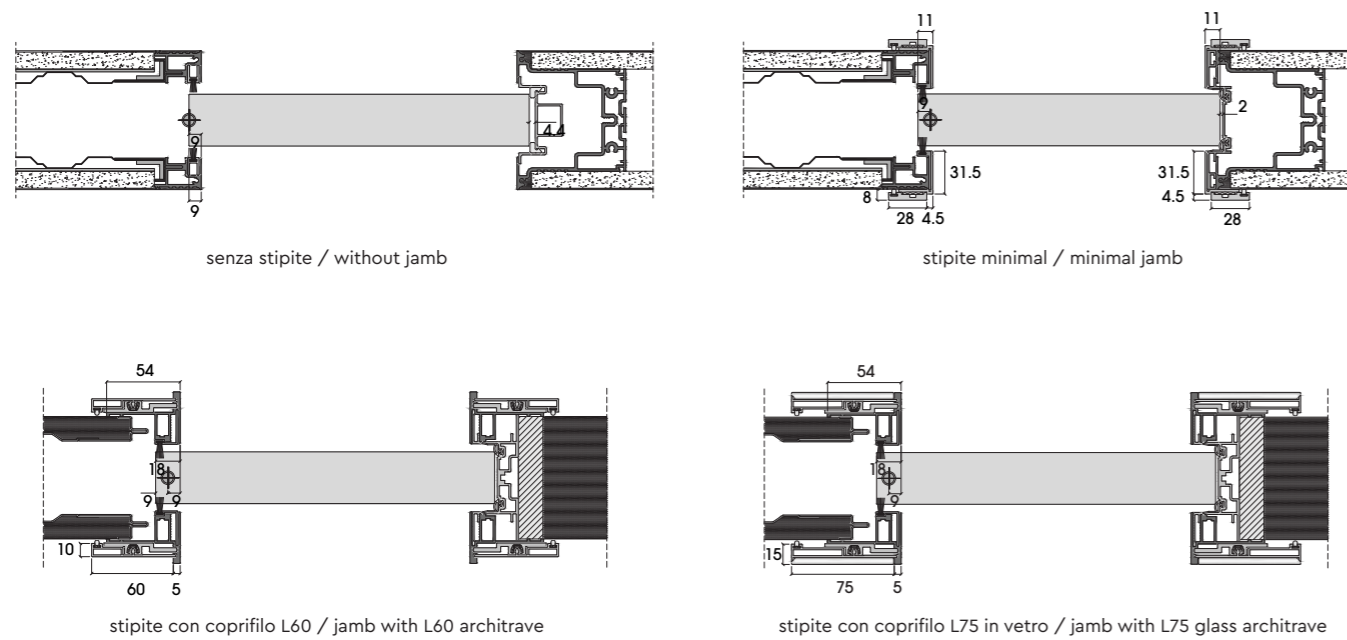
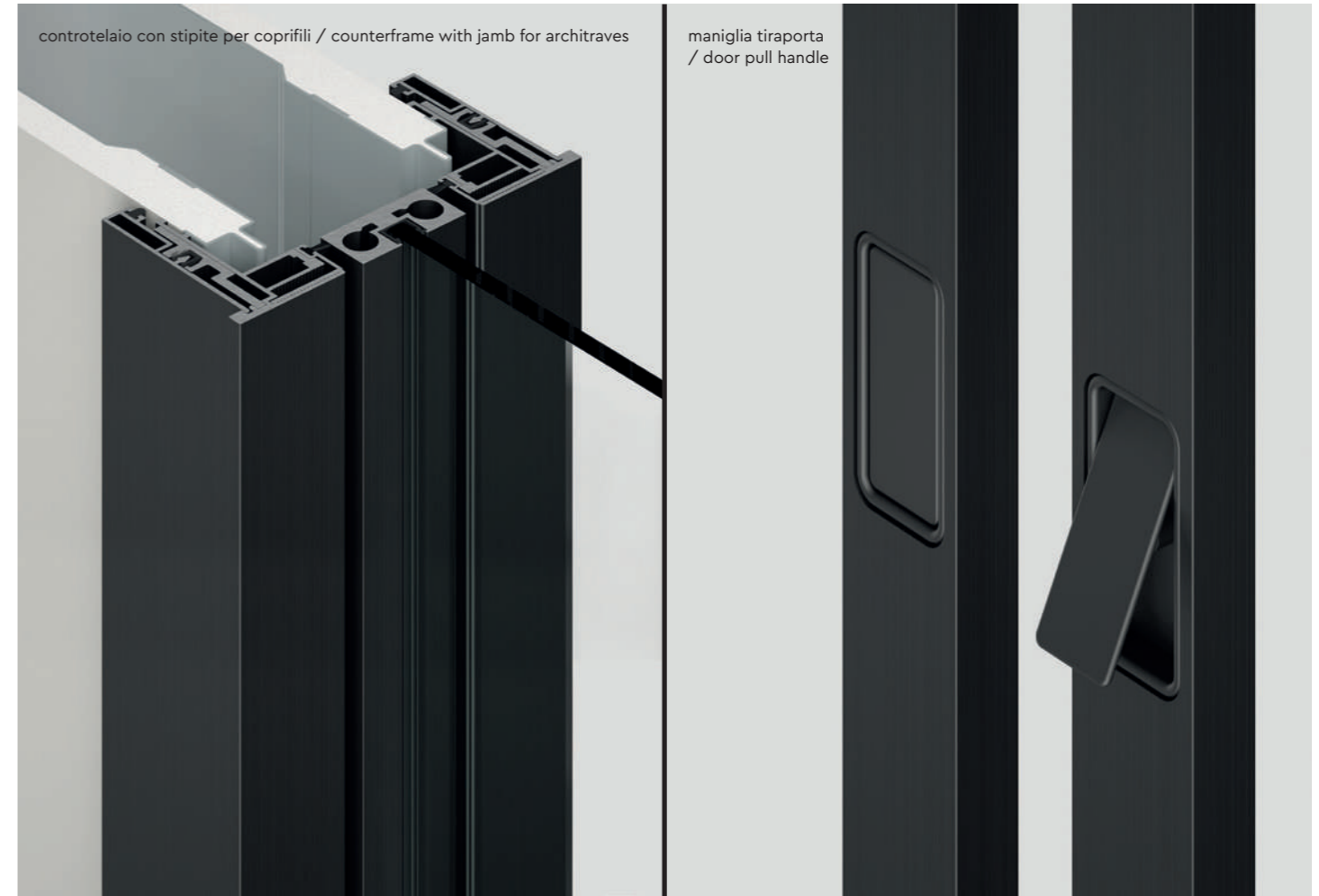

CARATTERISTICHE TECNICHE  
TECHNICAL FEATURES

Le caratteristiche variano leggermente in funzione del controtelaio installato, che determina la scelta tra senza stipite, stipite minimal o stipite per coprifili. In tutti i casi è di serie l'apertura totale e la maniglia tiraporta.

*The characteristics vary slightly, depending on the counter frame, which determines the elimination of the jamb, or the use of a minimal jamb or a cable cover jamb. In all cases, the full opening and a door handle are supplied as a standard.*

Las características varían un poco dependiendo del contramarco instalado que determina la elección entre sin jamba, jamba minimalista o jamba para cubrecables. En todos los casos es de serie la apertura total y la manilla tirador.

*Les caractéristiques varient légèrement en fonction du contre-cadre installé, ce qui détermine le choix entre finition sans chambranle, chambranle minimal ou chambranle pour goulottes électriques. Dans tous les cas, l'ouverture totale et la poignée pour tirer et fermer la porte sont fournies en série.*

Die Eigenschaften unterscheiden sich leicht je nach installiertem Gegenrahmen, der festlegt, ob die Tür ohne Zarge, mit minimaler Zarge oder mit Zargenabdeckungen installiert wird. Serienmäßig sind immer die maximale Öffnungsweite und der Griff zum Ziehen der Tür.